

**CBCP68 NPN
CBCP69 PNP**

**SURFACE MOUNT
COMPLEMENTARY
SMALL SIGNAL SILICON
TRANSISTORS**

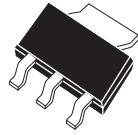

SOT-223 CASE

CentralTM

Semiconductor Corp.

DESCRIPTION:

The CENTRAL SEMICONDUCTOR, CBCP68, CBCP69 types are complementary silicon transistors manufactured by the epitaxial planar process, epoxy molded in a surface mount package, designed for applications requiring high current capability.

MARKING CODE: FULL PART NUMBER

MAXIMUM RATINGS: ($T_A=25^\circ\text{C}$)

	SYMBOL		UNITS
Collector-Emitter Voltage	V_{CES}	25	V
Collector-Emitter Voltage	V_{CEO}	20	V
Emitter-Base Voltage	V_{EBO}	5.0	V
Collector Current	I_C	1.0	A
Collector Current-Peak	I_{CM}	2.0	A
Base Current	I_B	100	mA
Base Current Peak	I_{BM}	200	mA
Power Dissipation	P_D	2.0	W
Operating and Storage			
Junction Temperature	T_J, T_{stg}	-65 to +150	$^\circ\text{C}$
Thermal Resistance	θ_{JA}	62.5	$^\circ\text{C/W}$

ELECTRICAL CHARACTERISTICS: ($T_A=25^\circ\text{C}$ unless otherwise noted)

SYMBOL	TEST CONDITIONS	MIN	TYP	MAX	UNITS
I_{CBO}	$V_{CB}=25\text{V}$			10	μA
I_{CBO}	$V_{CB}=25\text{V}, T_A=150^\circ\text{C}$			1.0	mA
I_{EBO}	$V_{EB}=5.0\text{V}$			10	μA
BV_{CBO}	$I_C=10\mu\text{A}$	25			V
BV_{CEO}	$I_C=10\text{mA}$	20			V
BV_{EBO}	$I_E=1.0\mu\text{A}$	5.0			V
$V_{CE(SAT)}$	$I_C=1.0\text{A}, I_B=100\text{mA}$			0.5	V
$V_{BE(ON)}$	$V_{CE}=10\text{V}, I_C=5.0\text{mA}$		0.6		V
$V_{BE(ON)}$	$V_{CE}=1.0\text{V}, I_C=1.0\text{A}$			1.0	V
h_{FE}	$V_{CE}=10\text{V}, I_C=5.0\text{mA}$	50			
h_{FE}	$V_{CE}=1.0\text{V}, I_C=500\text{mA}$	85		375	
h_{FE}	$V_{CE}=1.0\text{V}, I_C=1.0\text{A}$	60			
f_T	$V_{CE}=5.0\text{V}, I_C=10\text{mA}, f=20\text{MHz}$	65			MHz
C_{ob}	$V_{CB}=5.0\text{V}, I_E=0, f=450\text{kHz}$		25		pF

MECHANICAL OUTLINE - SOT-223

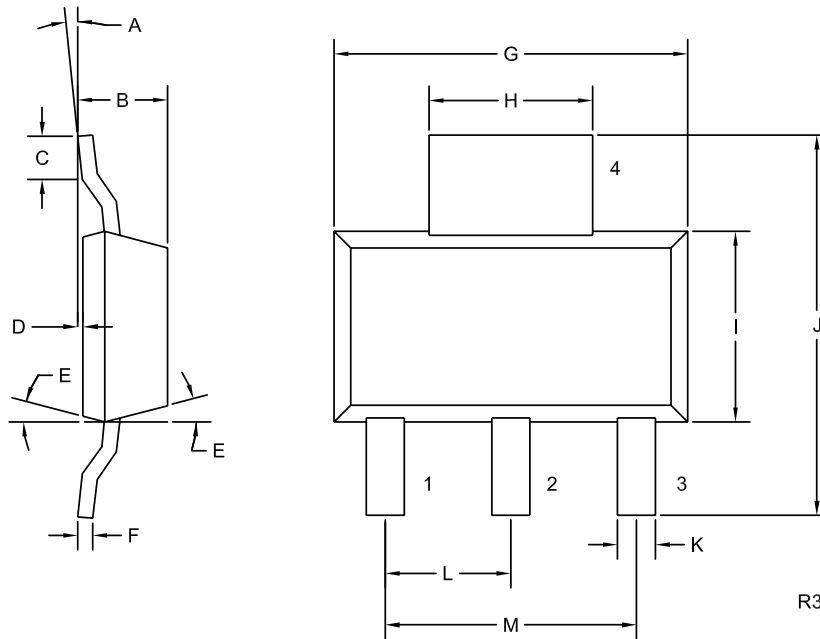

LEAD CODE:

- 1) BASE
- 2) COLLECTOR
- 3) EMITTER
- 4) COLLECTOR

MARKING CODE:

FULL PART NUMBER

SYMBOL	DIMENSIONS		DIMENSIONS	
	INCHES		MILLIMETERS	
	MIN	MAX	MIN	MAX
A	0°	10°	0°	10°
B	0.059	0.071	1.50	1.80
C	0.018	---	0.45	---
D	0.000	0.004	0.00	0.10
E	15°		15°	
F	0.009	0.014	0.23	0.35
G	0.248	0.264	6.30	6.70
H	0.114	0.122	2.90	3.10
I	0.130	0.146	3.30	3.70
J	0.264	0.287	6.70	7.30
K	0.024	0.033	0.60	0.85
L	0.091		2.30	
M	0.181		4.60	

SOT-223 (REV: R3)

R4 (17-June 2004)